

The information in this document is subject to change without notice and should not be construed as a commitment by ABB. ABB assumes no responsibility for any errors that may appear in this document.

Except as may be expressly stated anywhere in this document, nothing herein shall be construed as any kind of guarantee or warranty by ABB for losses, damages to persons or property, fitness for a specific purpose or the like.

In no event shall ABB be liable for incidental or consequential damages arising from use of this document.

This document and parts thereof must not be reproduced or copied without ABB's written permission, and contents thereof must not be imparted to a third party nor be used for any unauthorized purpose. Contravention will be prosecuted.

Additional copies of this document may be obtained from ABB at its then current charge.

© Copyright 2021 ABB ALL right reserved.

ABB Engineering (Shanghai) Ltd
No.4528, Kangxin Highway, Kangqiao Town
Pudong New District, Shanghai, 201319
P.R.China

Latest revision: Copyright updated.			Lab/Office: RA/RDP	CRB1100 COPYRIGHT PAGE	Status: Approved	Plant: = Location: + Sublocation: +	Document no. 3HAC076518-003	Rev. Ind 01	Page 1 Next 2 Total 17
Prepared by, date: CNQIL12	Approved by, date: CNJOHAU								

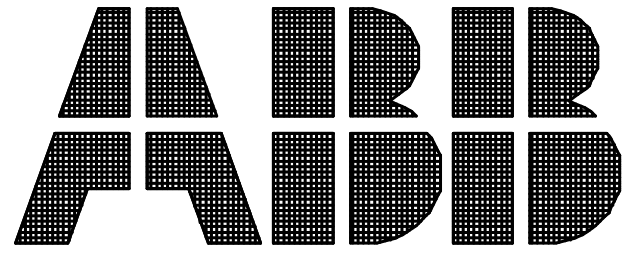

Description : CRB1100
Drawing number : 3HAC076518-003
Drawing version : 01
Date :

Customer :
Year of construction :

Drawn by : CNQILI2
Number of pages : 17

Latest revision:
Copyright updated.
Prepared by, date: CNQILI2
Approved by, date: CNJOHAU



Lab/Office:
RA/RDP

CRB1100
TITLE PAGE

Status:
Approved

Plant: =
Location: +
Sublocation: +

Document no.
3HAC076518-003

Rev. Ind
01

Page 2
Next 3
Total 17

TABLE OF CONTENTS

PAGE	PAGE DESCRIPTION	Date	Edited by
/1	COPYRIGHT PAGE	10/16/2020	CNQIL12
/2	TITLE PAGE	12/27/2017	CNQIL12
/3	TABLE OF CONTENTS	3/31/2021	CNQIL12
/4	VALID FOR	3/31/2021	CNQIL12
/5	REVISION INFORMATION	3/31/2021	CNQIL12
/6	SYSTEM OVERVIEW	10/19/2020	CNQIL12
/7	CONNECTION POINT LOCATION	10/19/2020	CNQIL12
/8	BRAKE RELEASE UNIT	10/16/2020	CNQIL12
/9	SERIAL MEASUREMENT BOARD	10/16/2020	CNQIL12
/10	AXIS 1	10/16/2020	CNQIL12
/11	AXIS 2	10/16/2020	CNQIL12
/12	AXIS 3	10/16/2020	CNQIL12
/13	AXIS 4	10/16/2020	CNQIL12
/14	AXIS 5	10/16/2020	CNQIL12
/15	AXIS 6	10/16/2020	CNQIL12
/16	CUSTOMER CONNECTION AND LAMP	10/19/2020	CNQIL12
/17	ETHERNET CONNECTION AND LEADTHROUGH	10/19/2020	CNQIL12

We reserve all rights in this document and in the information contained therein. Reproduction, use or disclosure to third parties without express authority is strictly forbidden. © Copyright 2003 ABB

We reserve all rights in this document and in the information contained therein. Reproduction, use or disclosure to third parties without express authority is strictly forbidden. © Copyright 2003 ABB

Valid for:

This circuit diagram is valid for the following cable harness & board unit assemblies:

Harness for Robot:

3HAC060420-003 L Basic+CP/CS+4x4mm air hose+Eth.

3HAC060419-003 U Basic+CPCS+4x4mm air+Eth.

or

3HAC060416-003 U Basic+CPCS+4x4mm air+Eth.Ext.

3HAC76493-001 Process hub C1+4x4mm air+C2 +Muti-lamp

Board unit for Robot:

3HAC063968-001 SMB Unit

3HAC044075-001 Battery Unit

Latest revision:
Copyright updated.

Prepared by, date: CNQIL12 Approved by, date: CNJOHAU



Lab/Office:
RA/RDP

CRB1100
VALID FOR

Status:
Approved

Plant: =
Location: +
Sublocation: +

Document no.
3HAC076518-003

Rev. Ind
01

Page 4
Next 5
Total 17

2020-10-15 First version Ver00

2021-03-31 Rev01
Copyright updated

We reserve all rights in this document and in the information contained therein. Reproduction, use or disclosure to third parties without express authority is strictly forbidden. © Copyright 2003 ABB

Latest revision: Copyright updated.	
Prepared by, date: CNQIL12	Approved by, date: CNJOHAU



Lab/Office:
RA/RDP

CRB1100 REVISION INFORMATION

Status: Approved	Plant: = Location: + Sublocation: +	Document no. 3HAC076518-003	Rev. Ind 01	Page 5 Next 6 Total 17
---------------------	---	--------------------------------	----------------	------------------------------

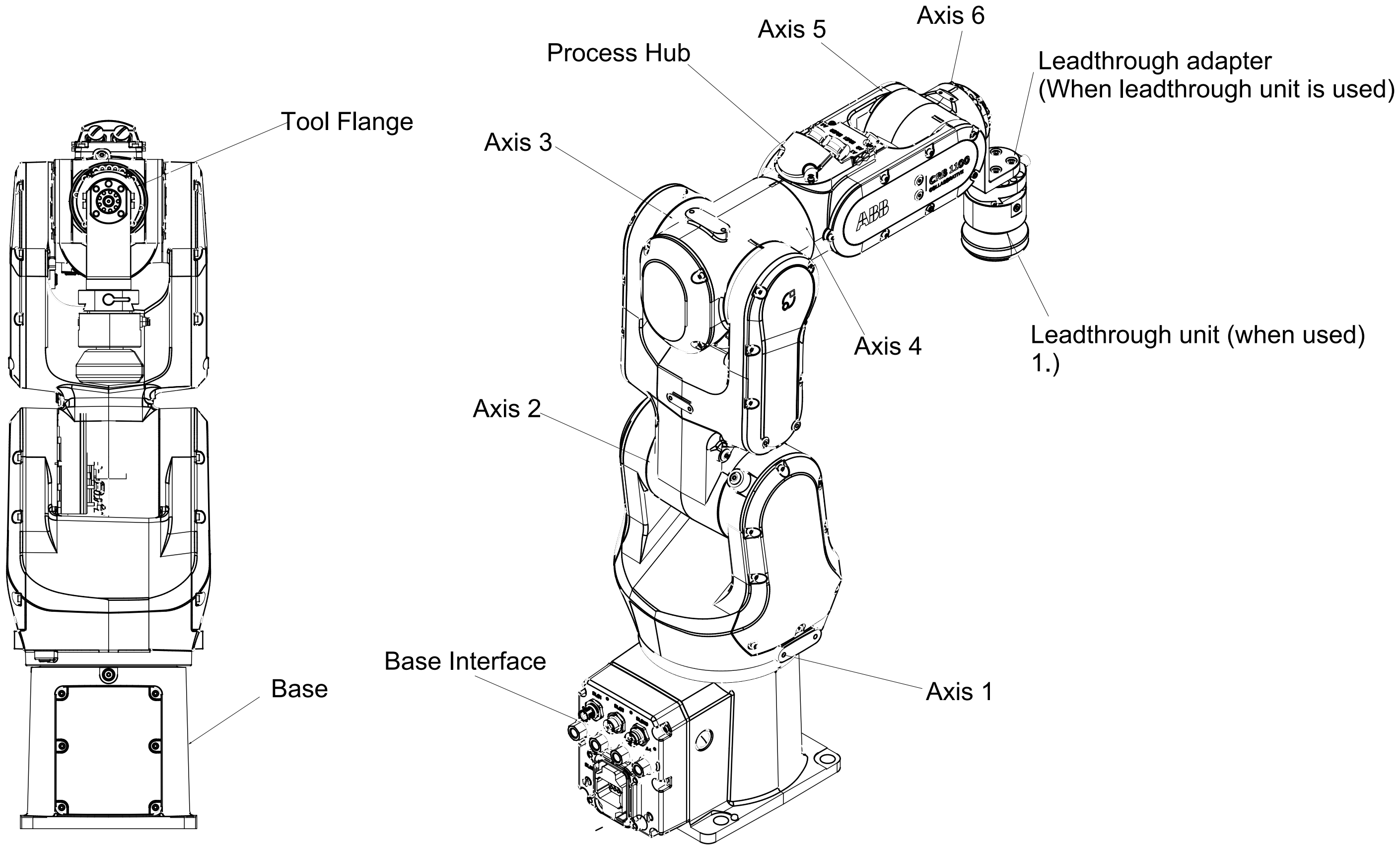

Note

1: How to operate the leadthrough unit will be described in product manual.

We reserve all rights in this document and in the information contained therein. Reproduction, use or disclosure to third parties without express authority is strictly forbidden. © Copyright 2003 ABB

Latest revision: Copyright updated.	Prepared by, date: CNQIL2	Approved by, date: CNJOHAU
--	---------------------------	----------------------------

ABB	Lab/Office: RA/RDP	CRB1100 SYSTEM OVERVIEW

Status: Approved	Plant: Location: Sublocation: +	Rev. Ind 01	Page 6 Next 7 Total 17
Document no. 3HAC076518-003			

We reserve all rights in this document and in the information contained therein. Reproduction, use or disclosure to third parties without express authority is strictly forbidden. © Copyright 2003 ABB

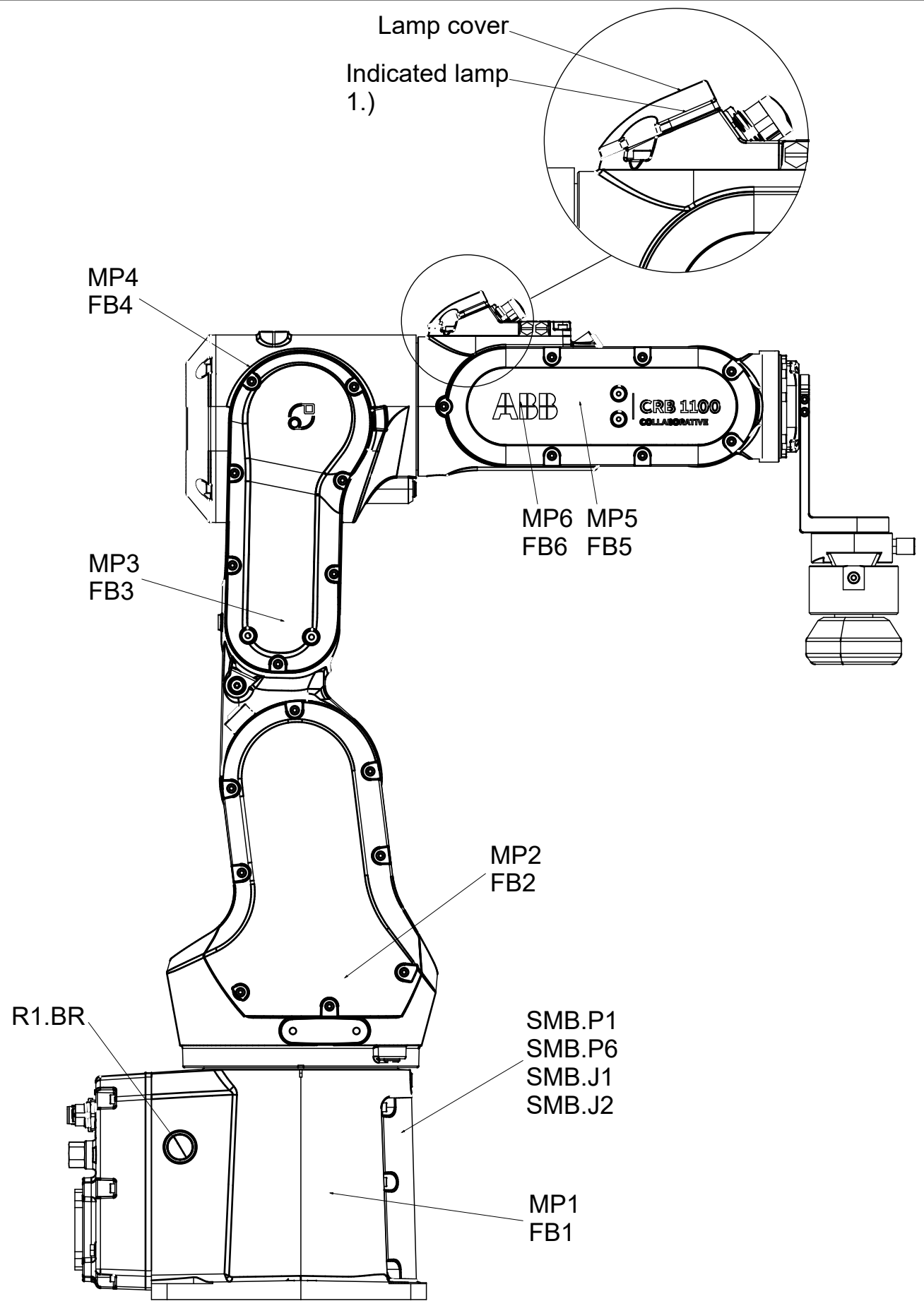
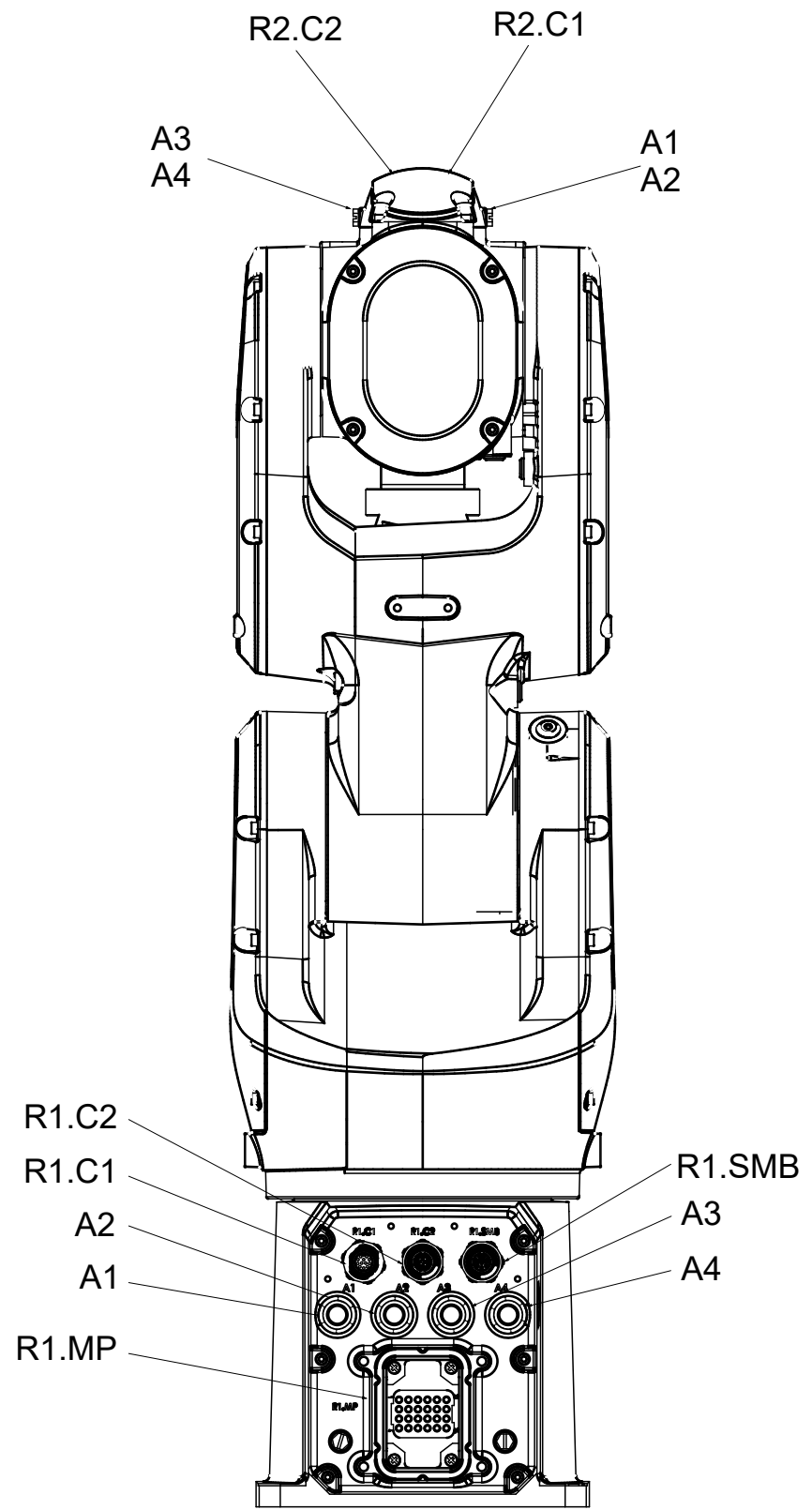

Note
 1: Further information about the lamp can be found in product manual.

Latest revision: Copyright updated.	Prepared by, date: CNQIL12	Approved by, date: CNJOHAU	 Lab/Office: RA/RDP	CRB1100 CONNECTION POINT LOCATION	Status: Approved	Plant: =	Document no. 3HAC076518-003	Rev. Ind 01	Page 7 Next 8 Total 17
					Location: +	Sublocation: +			

We reserve all rights in this document and in the information contained therein. Reproduction, use or disclosure to third parties without express authority is strictly forbidden. © Copyright 2003 ABB

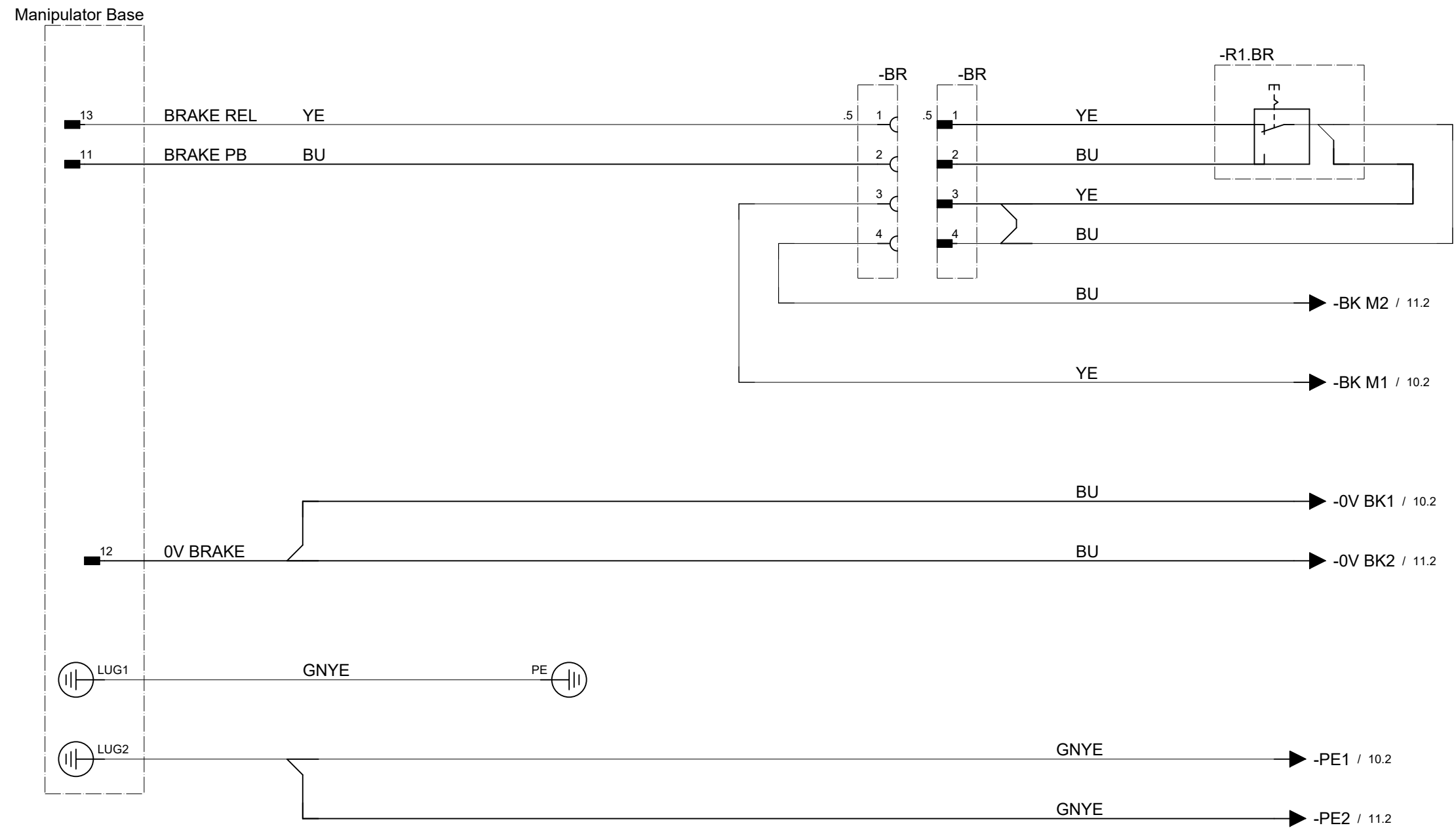

Latest revision:
Copyright updated.

Prepared by, date: CNQIL12 Approved by, date: CNJOHAU



Lab/Office:
RA/RDP

CRB1100
BRAKE RELEASE UNIT

Status: Approved Plant: =
Location: +
Sublocation: +

Document no. 3HAC076518-003 Rev. Ind 01 Page 8
Next 9
Total 17

We reserve all rights in this document and in the information contained therein. Reproduction, use or disclosure to third parties without express authority is strictly forbidden. © Copyright 2003 ABB

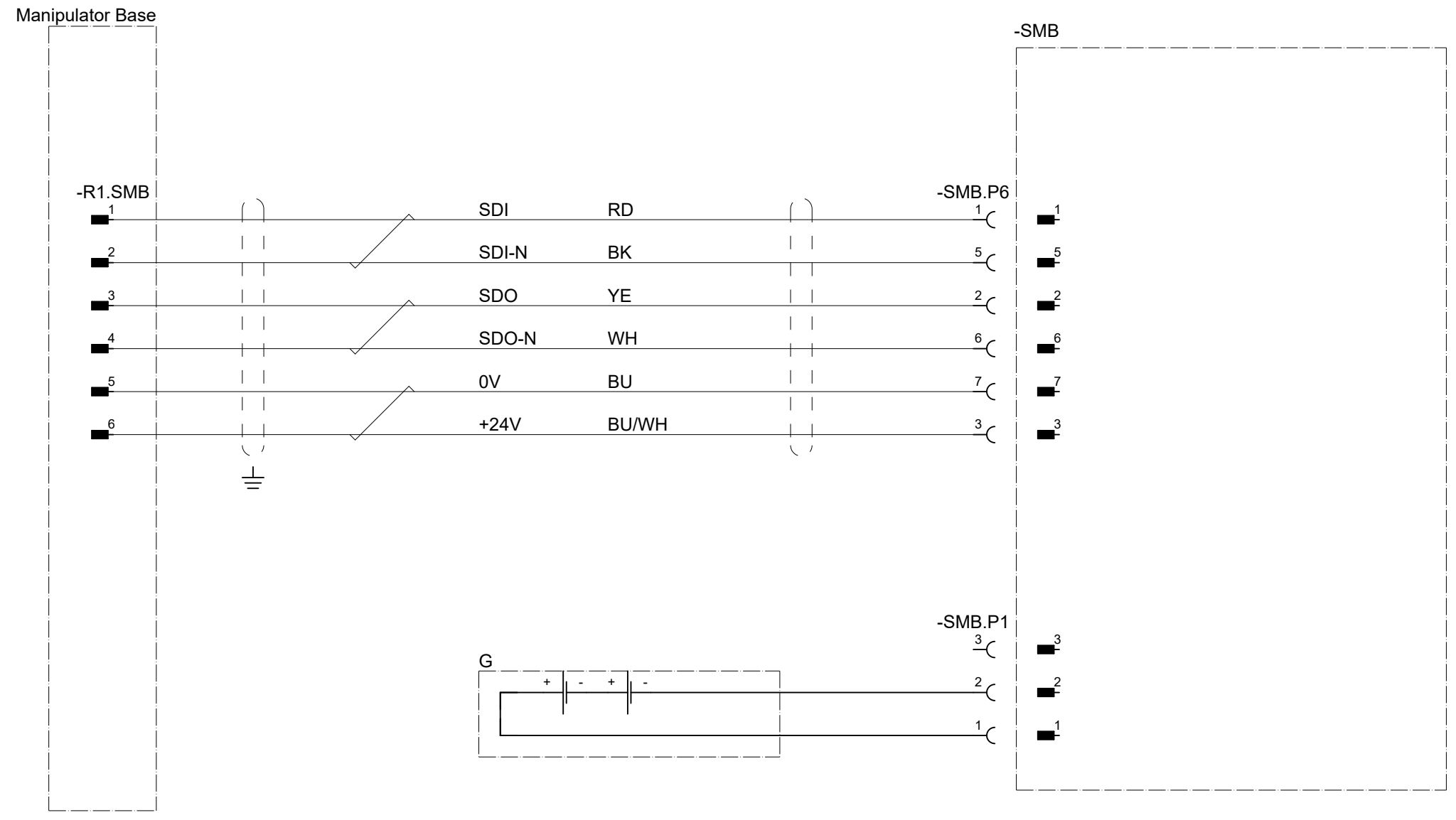

Latest revision:
Copyright updated.

Prepared by, date: CNQIL12 Approved by, date: CNJOHAU



Lab/Office:
RA/RDP

CRB1100
SERIAL MEASUREMENT BOARD

Status: Approved Plant: =
Location: +
Sublocation: +

Document no. 3HAC076518-003	Rev. Ind 01	Page 9 Next 10 Total 17
--------------------------------	----------------	-------------------------------

We reserve all rights in this document and in the information contained therein. Reproduction, use or disclosure to third parties without express authority is strictly forbidden. © Copyright 2003 ABB

Manipulator Base

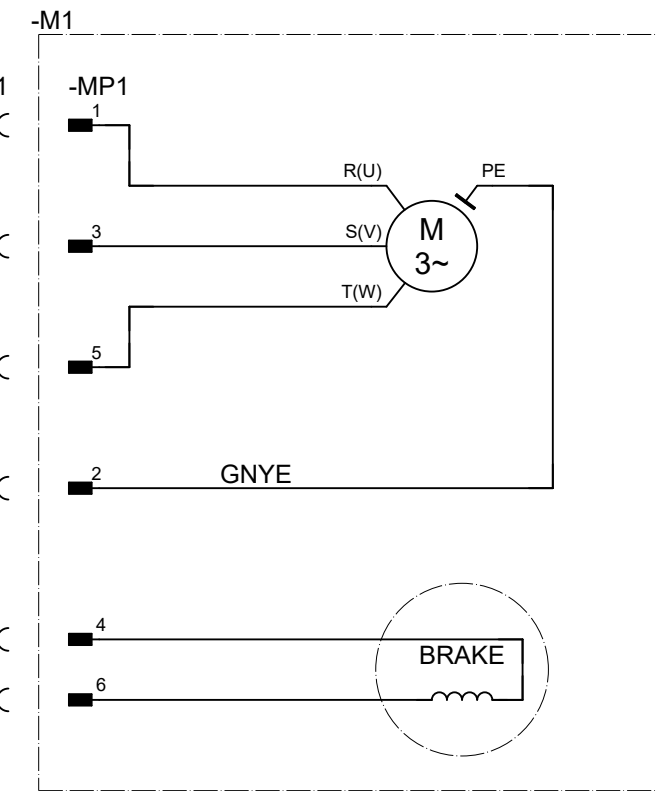
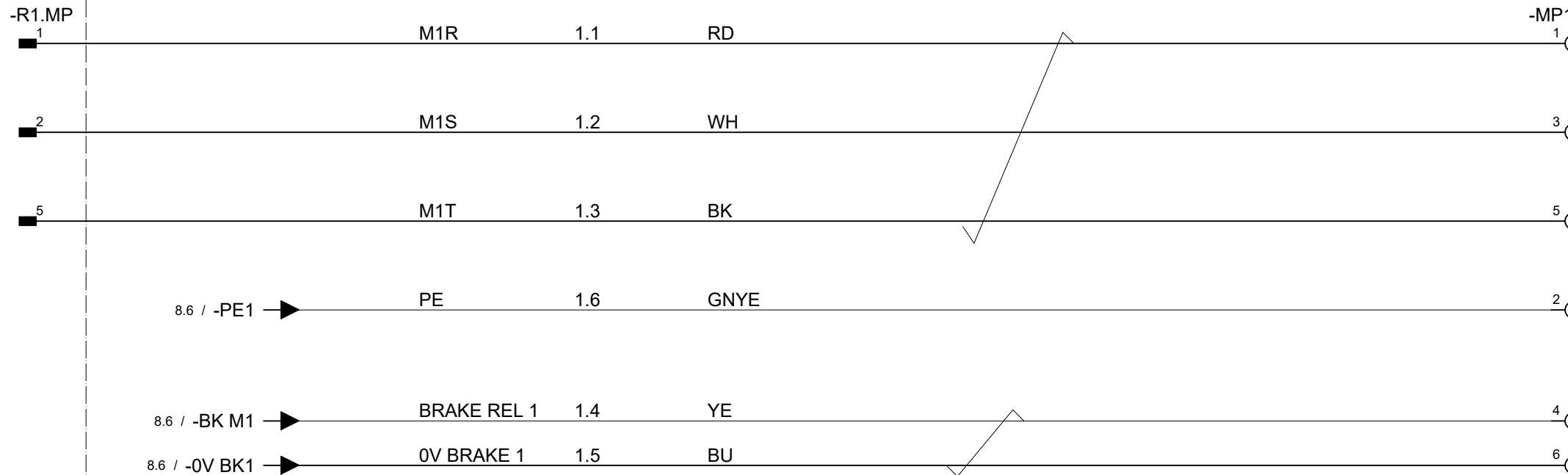

-SMB

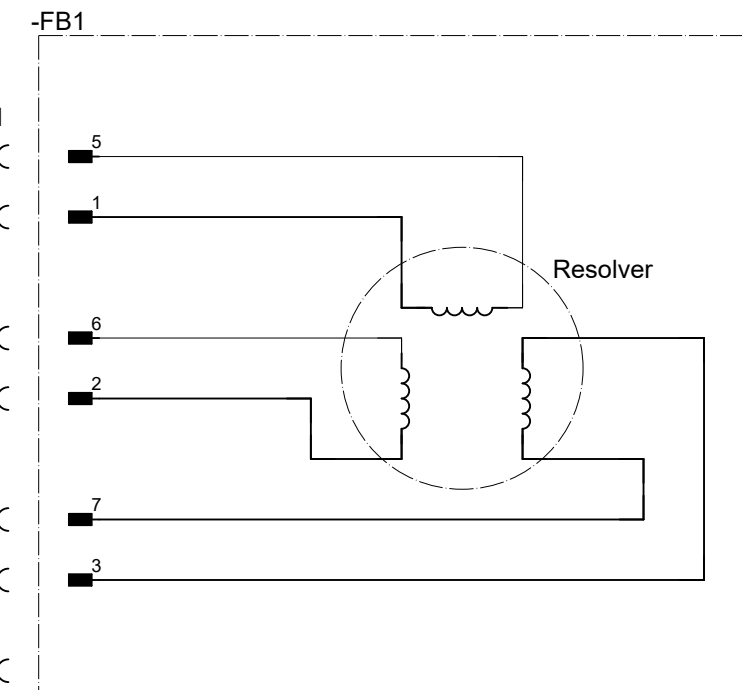
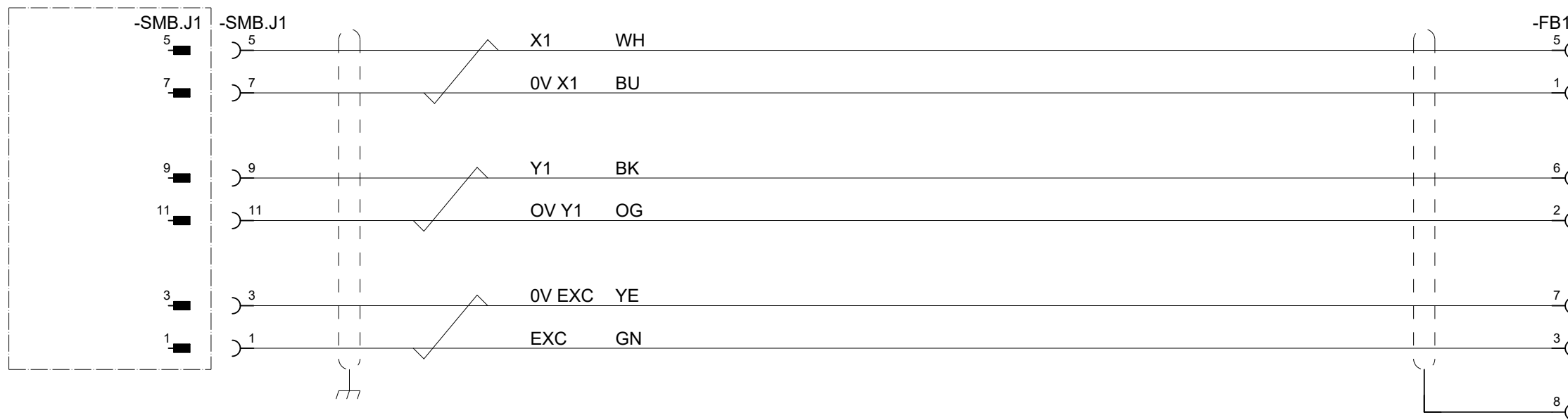

Latest revision:
Copyright updated.

Prepared by, date: CNQIL2 Approved by, date: CNJOHAU



Lab/Office:
RA/RDP

CRB1100
AXIS 1

Status: Approved

Plant: =
Location: +
Sublocation: +

Document no. 3HAC076518-003

Rev. Ind 01

Page 10
Next 11
Total 17

We reserve all rights in this document and in the information contained therein. Reproduction, use or disclosure to third parties without express authority is strictly forbidden. © Copyright 2003 ABB

Manipulator Base

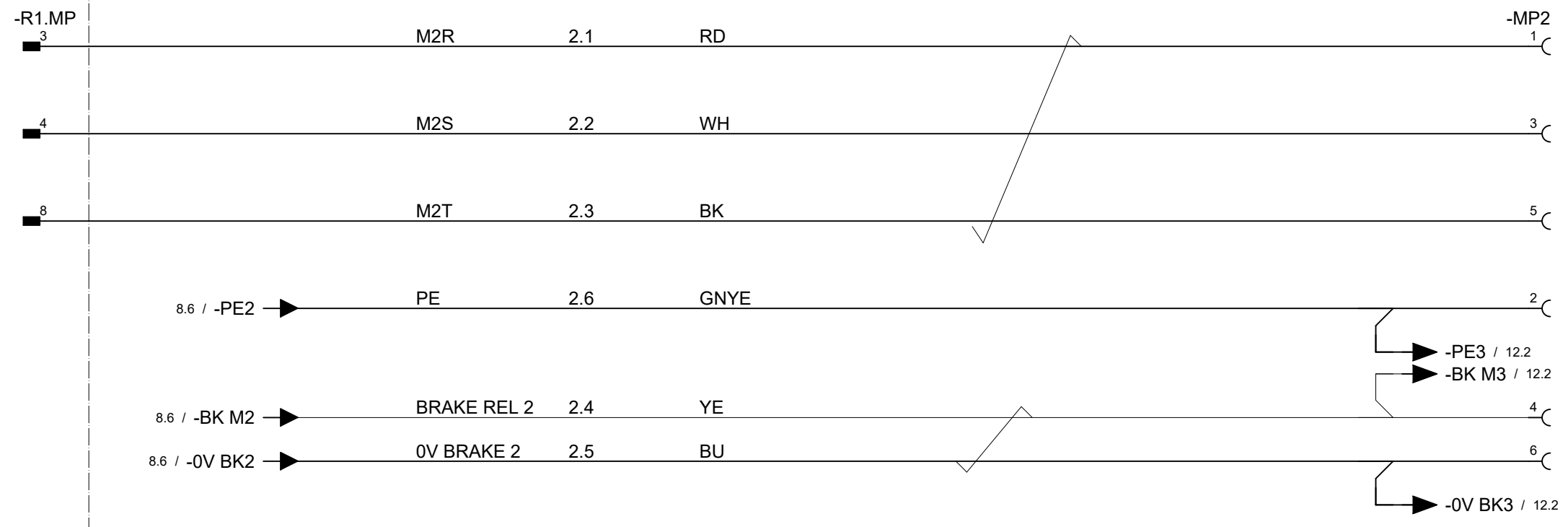

-M2

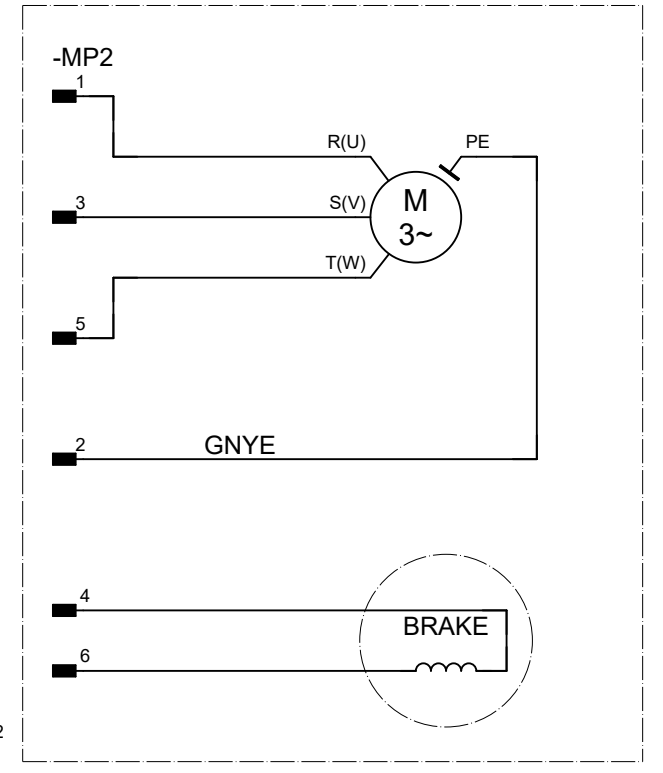

-SMB

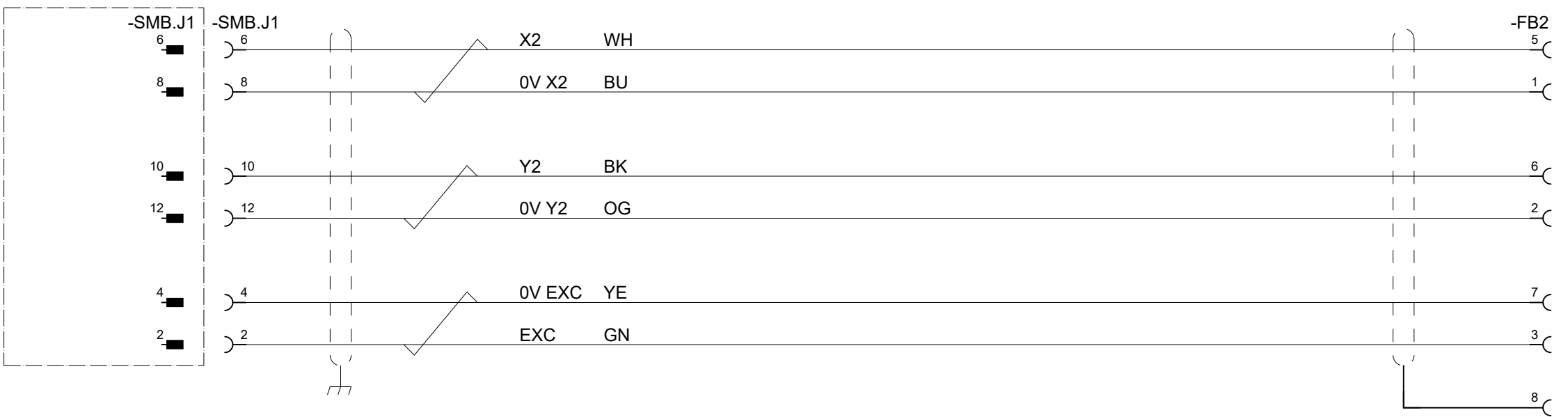

-FB2

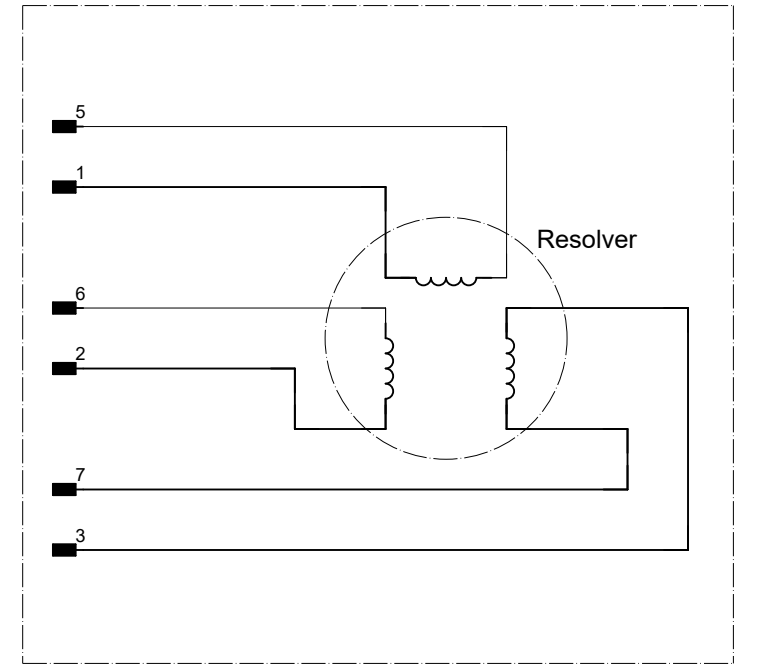

Latest revision:
Copyright updated.

Prepared by, date: CNQIL2 Approved by, date: CNJOHAU



Lab/Office:
RA/RDP

CRB1100
AXIS 2

Status:
Approved

Plant: =
Location: +
Sublocation: +

Document no. 3HAC076518-003	Rev. Ind 01	Page 11 Next 12 Total 17
--------------------------------	----------------	--------------------------------

We reserve all rights in this document and in the information contained therein. Reproduction, use or disclosure to third parties without express authority is strictly forbidden. © Copyright 2003 ABB

Manipulator Base

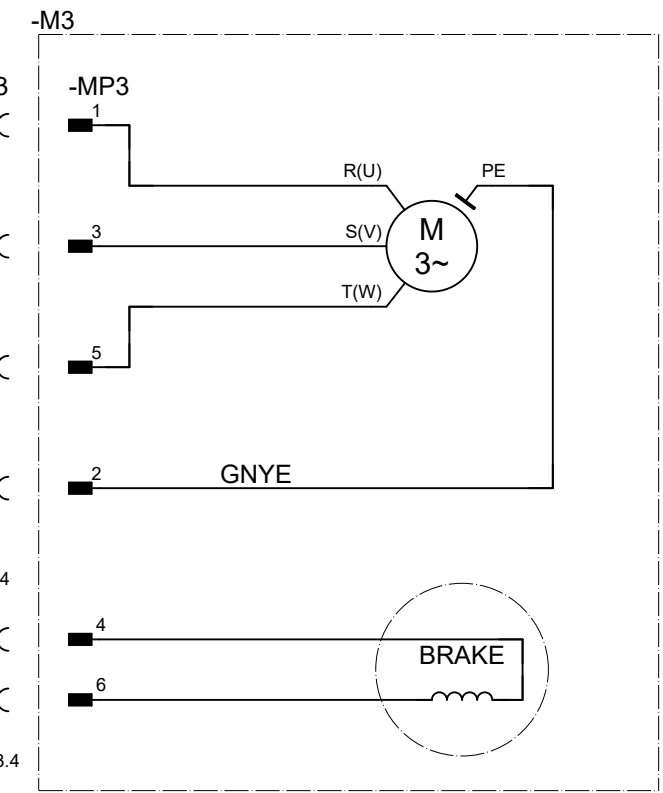
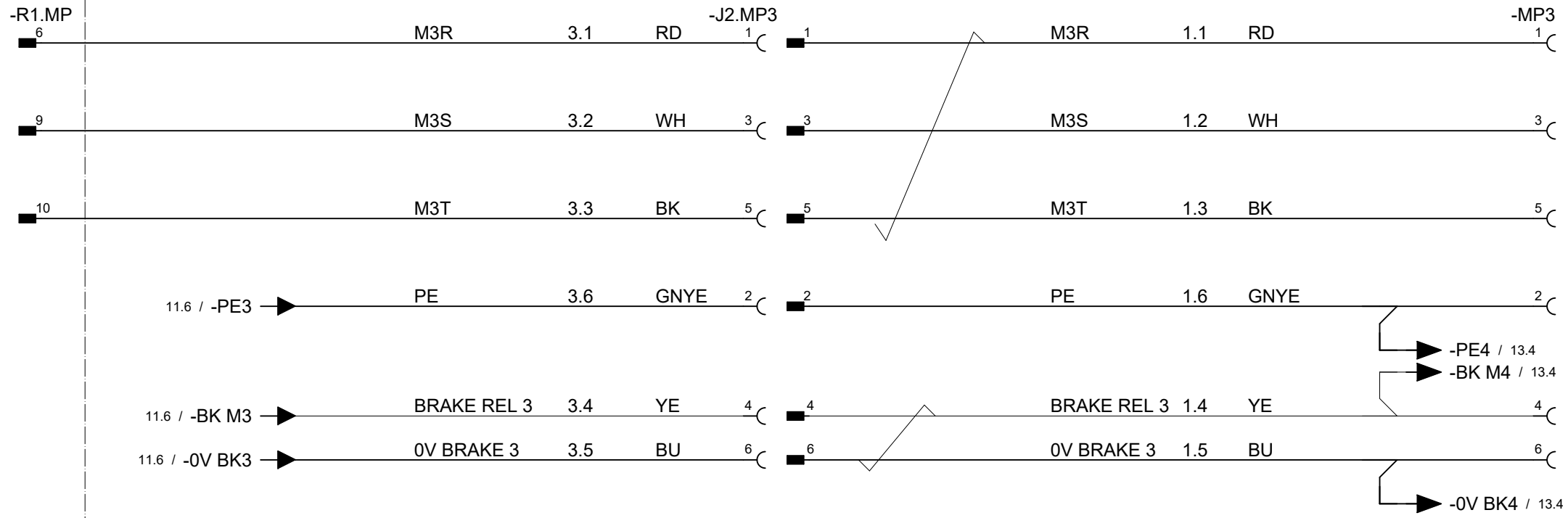

-SMB

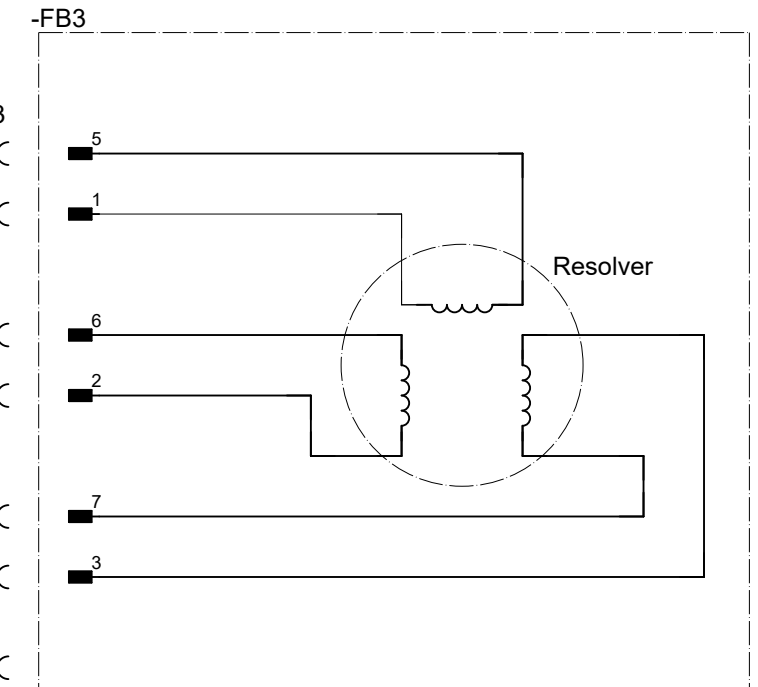
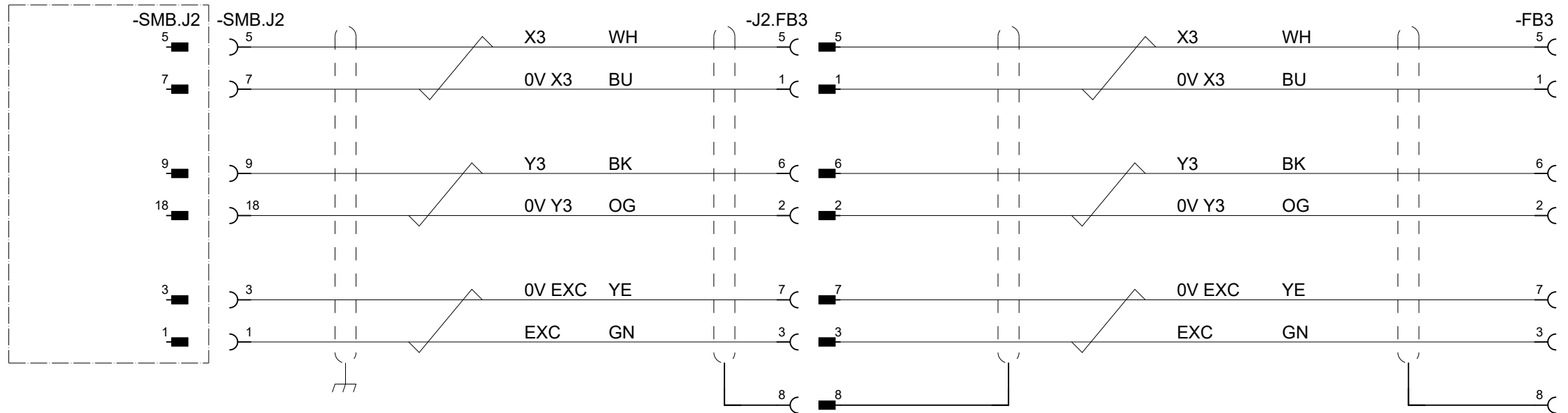

We reserve all rights in this document and in the information contained therein. Reproduction, use or disclosure to third parties without express authority is strictly forbidden. © Copyright 2003 ABB

Manipulator Base

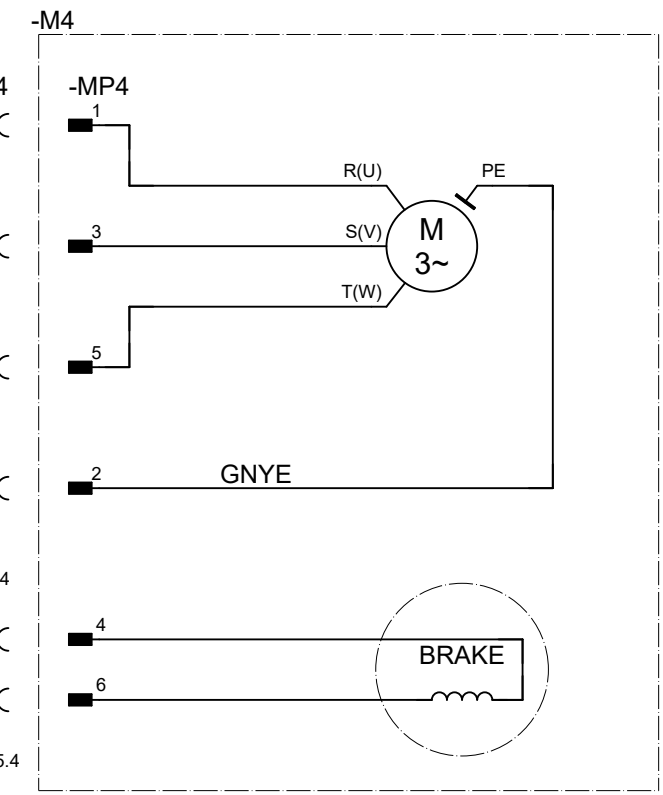
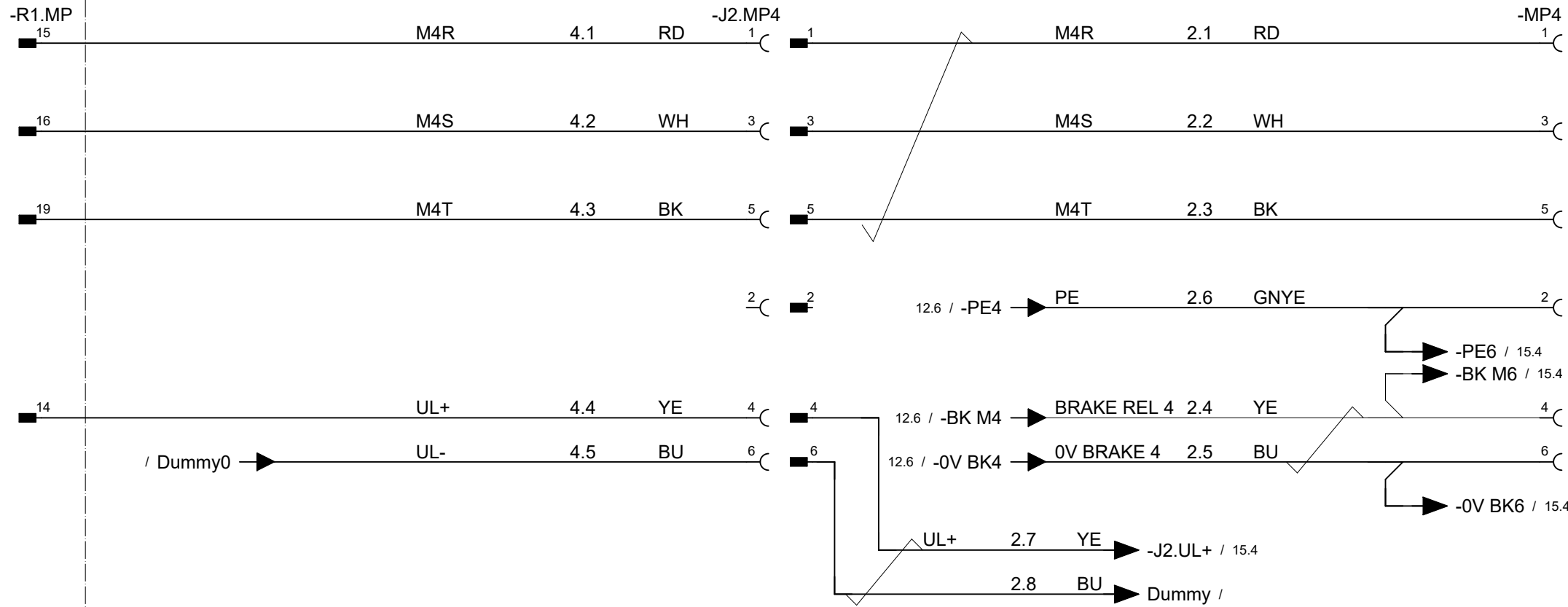

-SMB

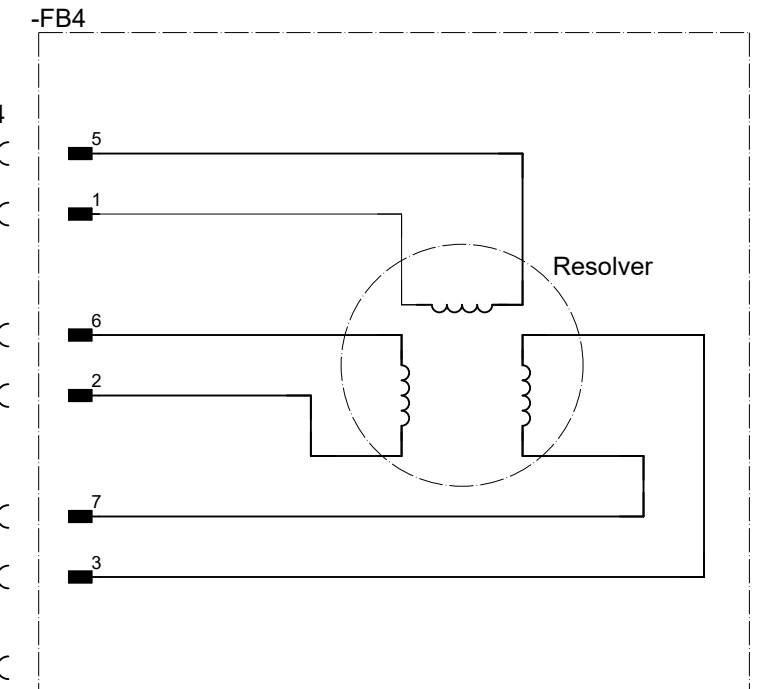
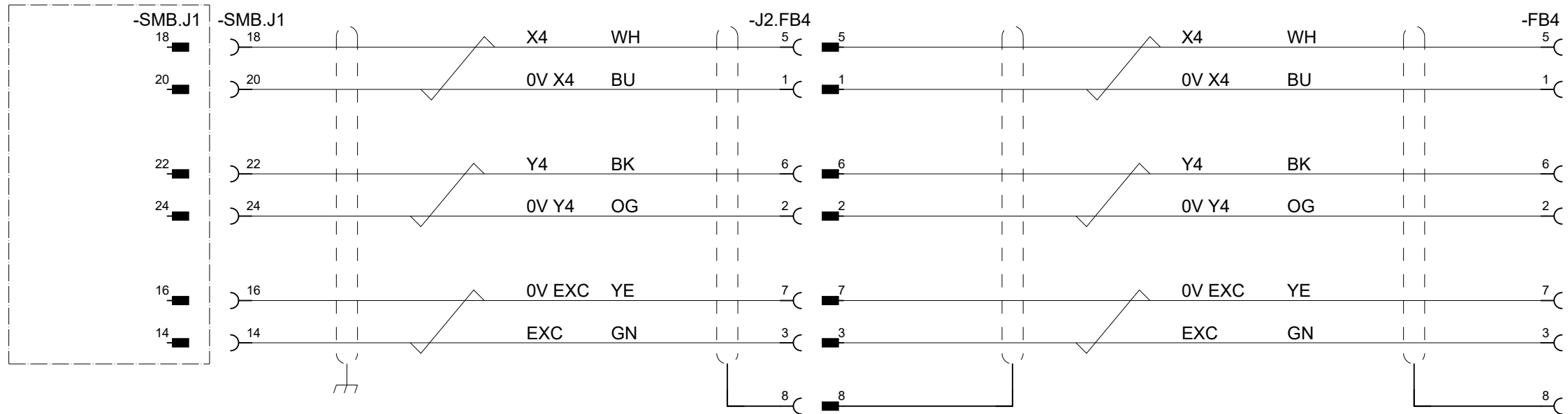

We reserve all rights in this document and in the information contained therein. Reproduction, use or disclosure to third parties without express authority is strictly forbidden. © Copyright 2003 ABB

Manipulator Base

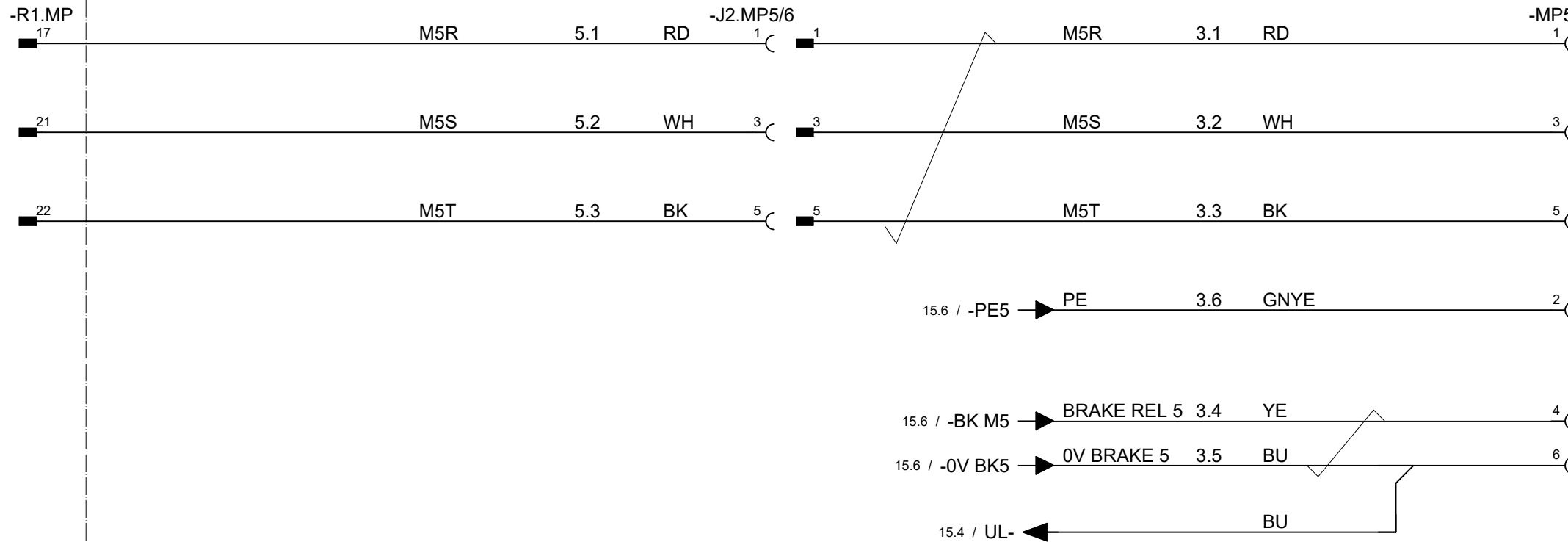

-M5

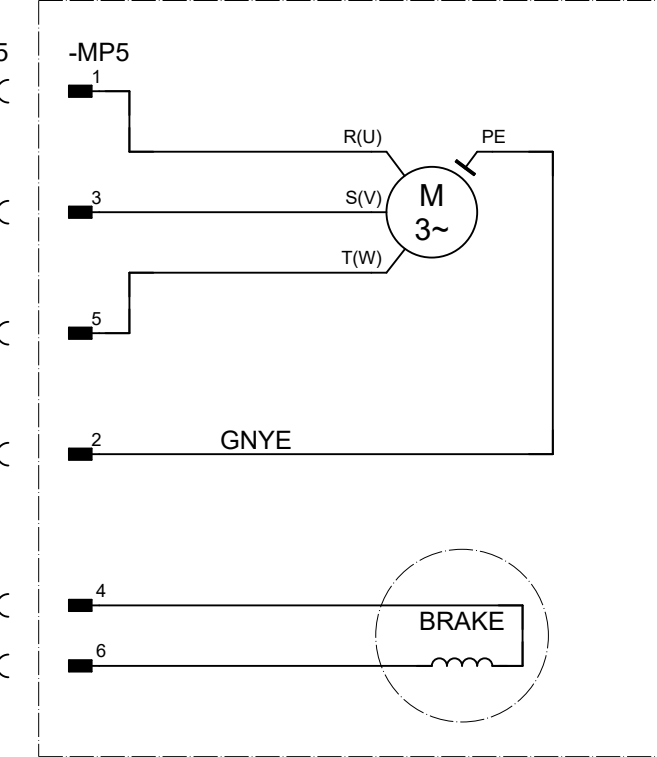

-SMB

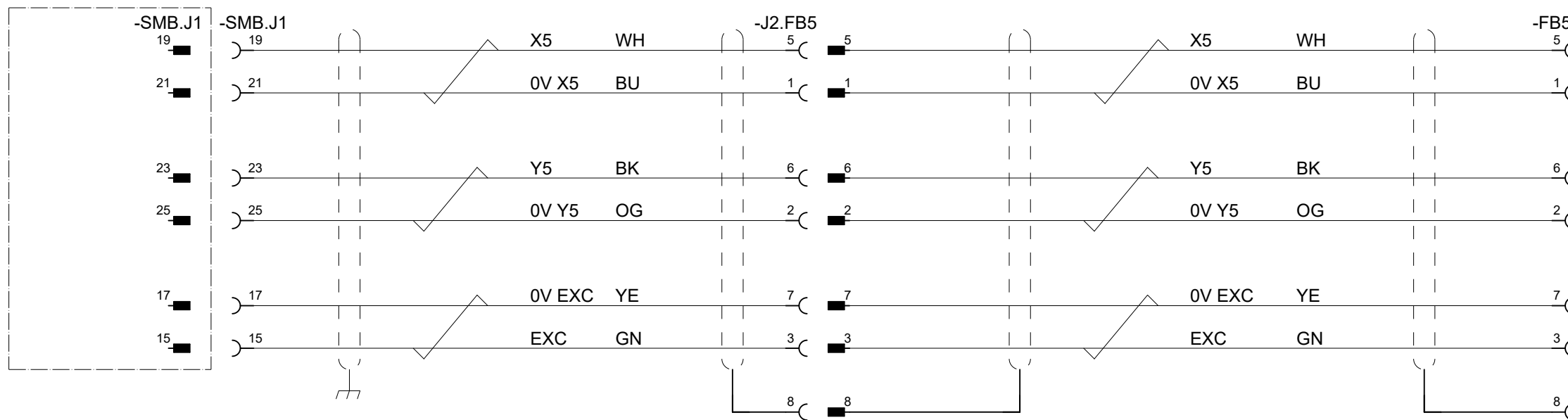

-FB5

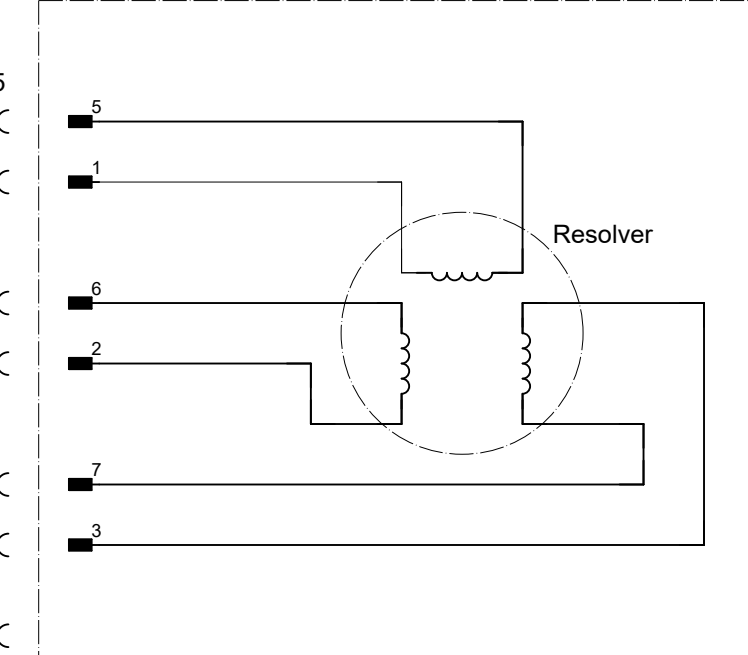

We reserve all rights in this document and in the information contained therein. Reproduction, use or disclosure to third parties without express authority is strictly forbidden. © Copyright 2003 ABB

Manipulator Base

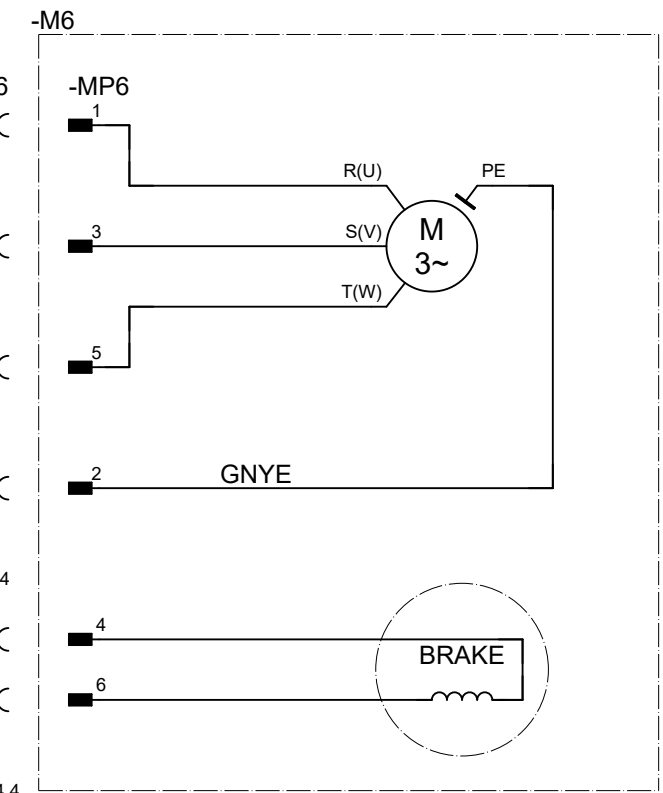
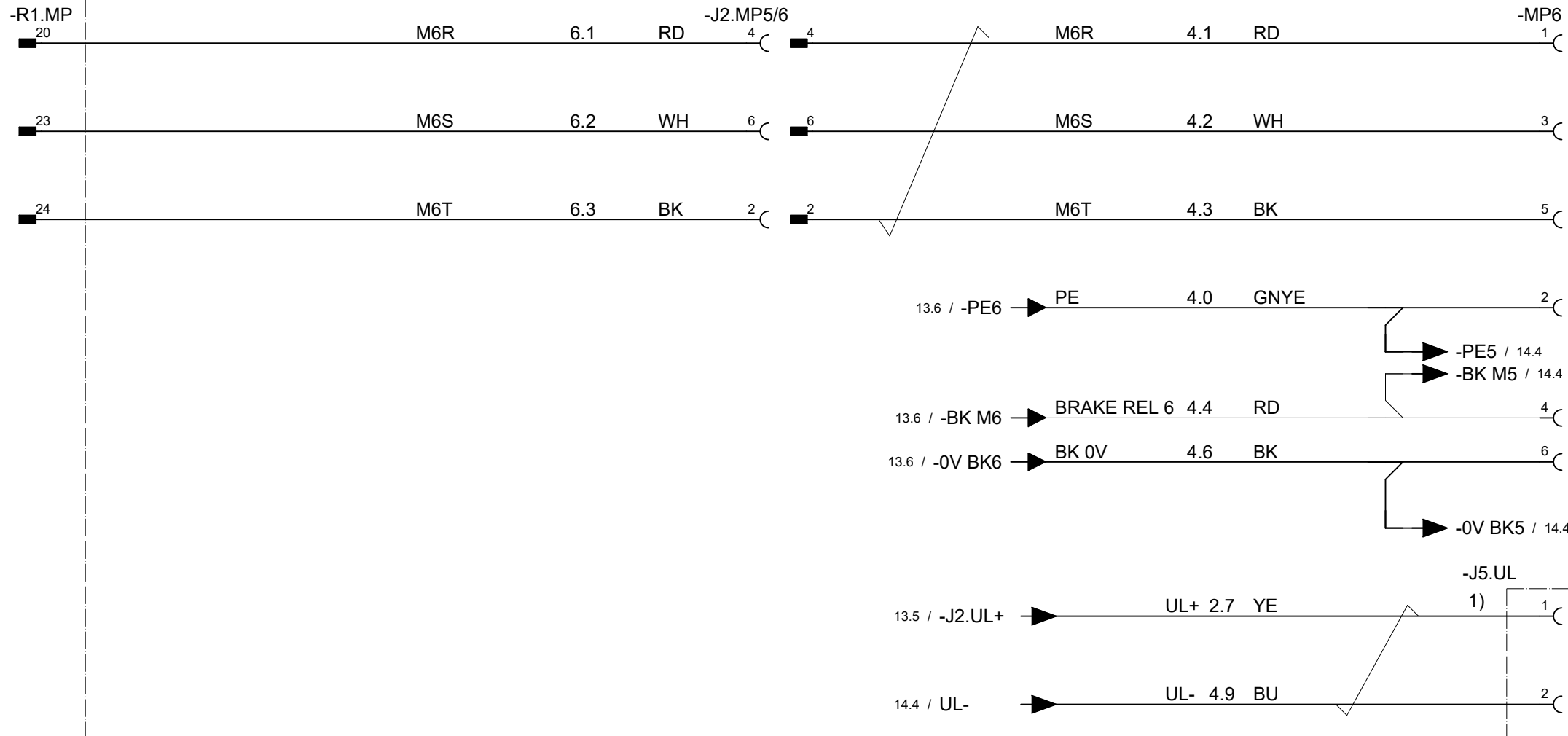

-SMB

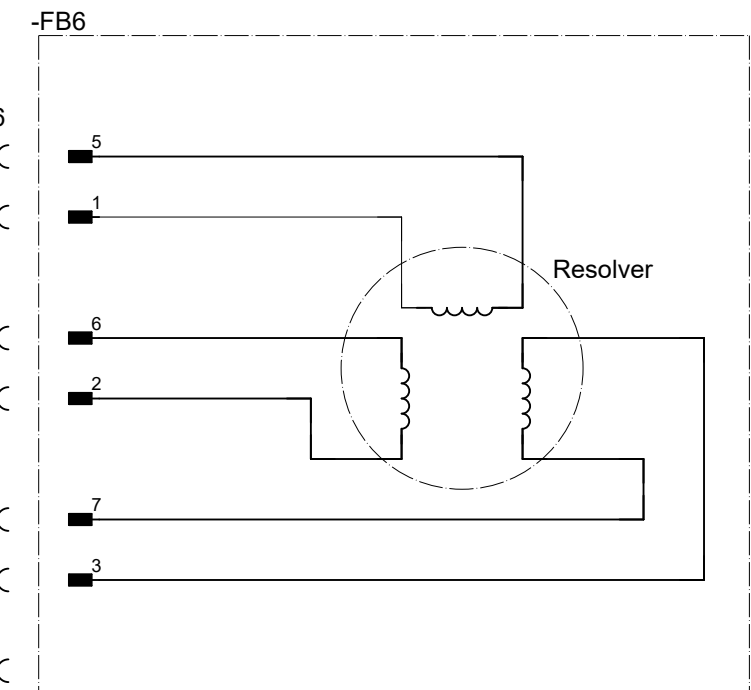
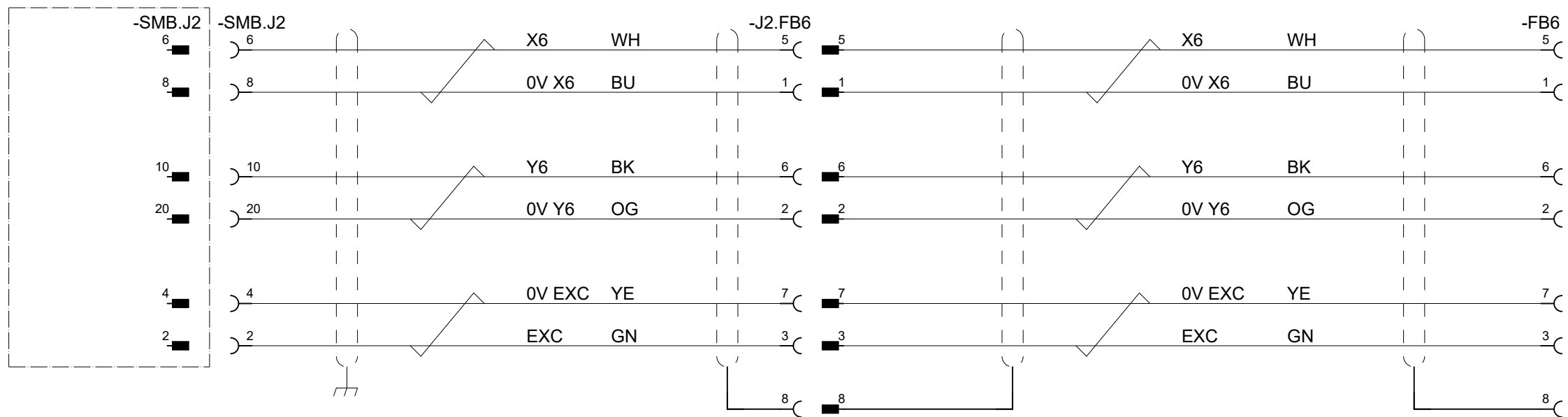

Latest revision:
Copyright updated.

Prepared by, date: CNQIL2 Approved by, date: CNJOHAU

ABB Lab/Office:
RA/RDP

CRB1100
AXIS 6

Status: Approved Plant: =
Location: +
Sublocation: +

Document no. 3HAC076518-003 Rev. Ind 01 Page 15
Next 16
Total 17

We reserve all rights in this document and in the information contained therein. Reproduction, use or disclosure to third parties without express authority is strictly forbidden. © Copyright 2003 ABB

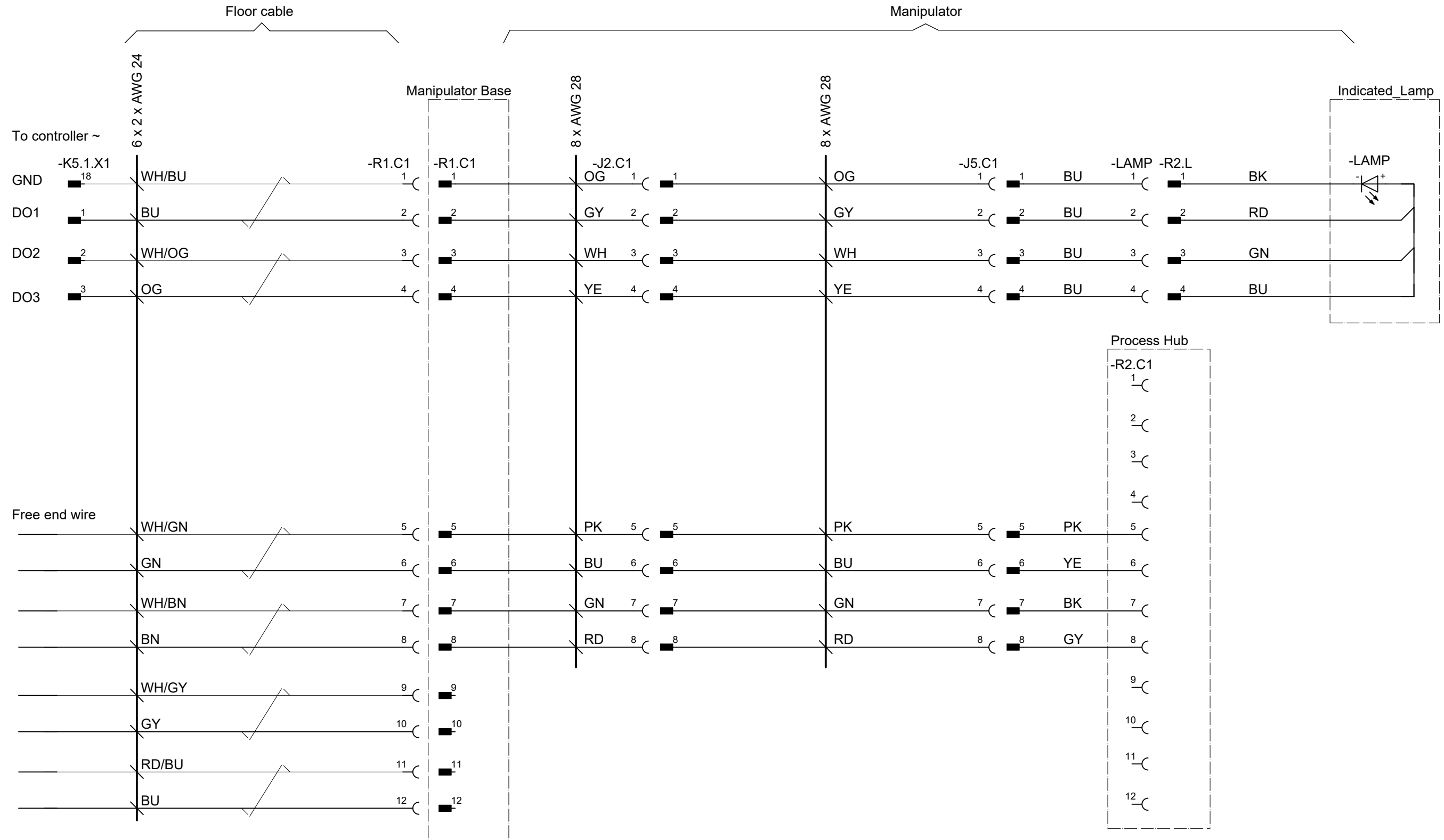

Note : 1) Maximum rating in each C1 wire: 30V, 1.5A. Stresses above the limitation may cause permanent damage to the manipulator.

Latest revision: Copyright updated.	Prepared by, date: CNQIL2	Approved by, date: CNJOHAU		Lab/Office: RA/RDP	CRB1100 CUSTOMER CONNECTION AND LAMP	Status: Approved	Plant: Location: Sublocation: = + +	Document no.	Rev. Ind	Page 16
								3HAC076518-003	01	Next 17 Total 17

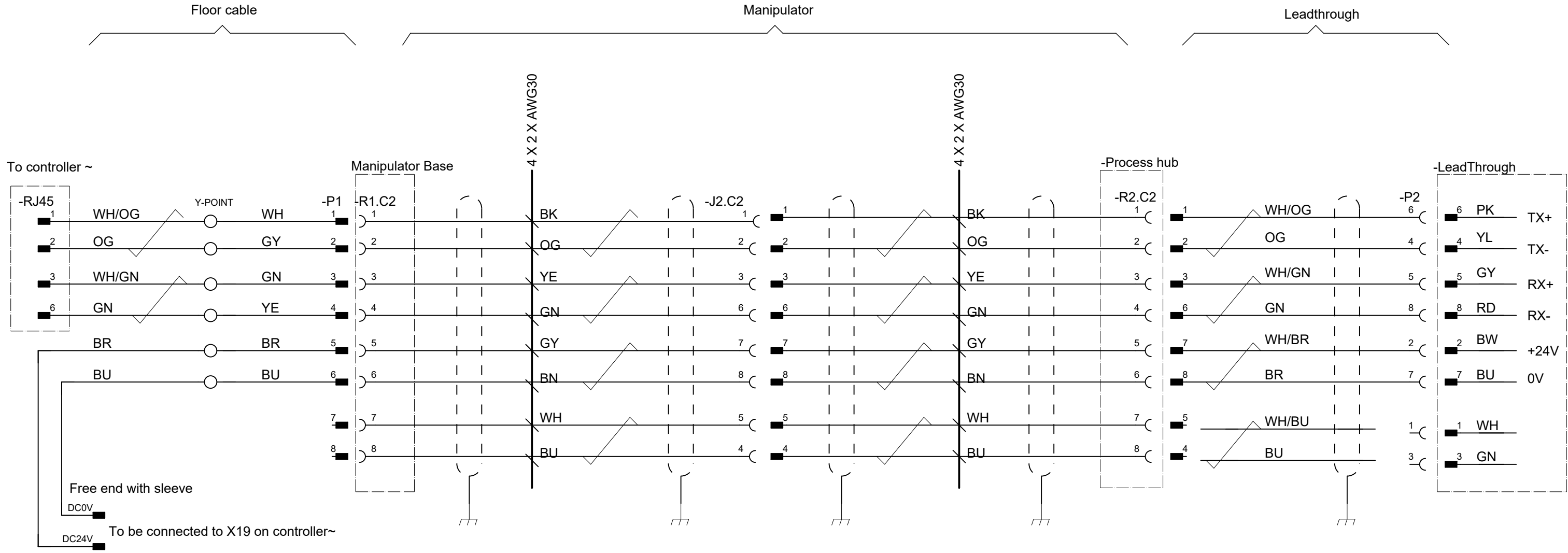

Note : 1): Ethernet cable connecting instruction 3HAC063936-005
 2): Maximum rating in each C2 wire: 30V, 1A (when not using for Ethernet). Stresses above the limitation may cause permanent damage to the manipulator.

We reserve all rights in this document and in the information contained therein. Reproduction, use or disclosure to third parties without express authority is strictly forbidden. © Copyright 2003 ABB